

2954 TWO-POINT DEADLOCK

DIMENSIONS

INCHES
MILLIMETERS

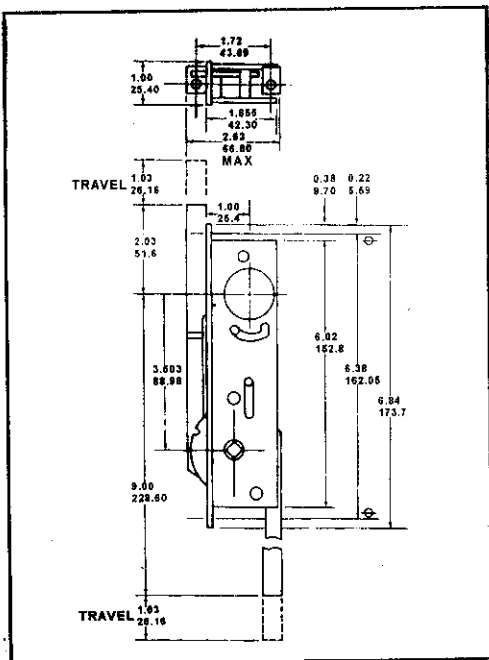

INSTALLATION

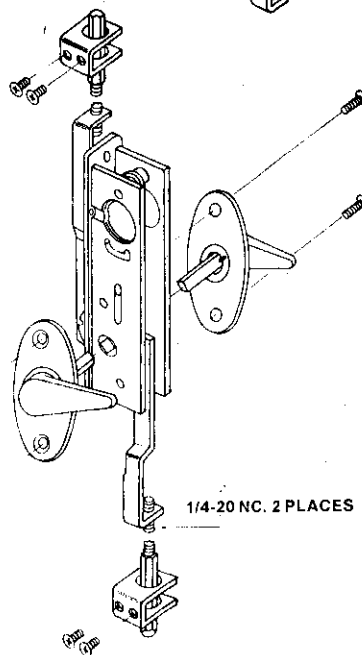
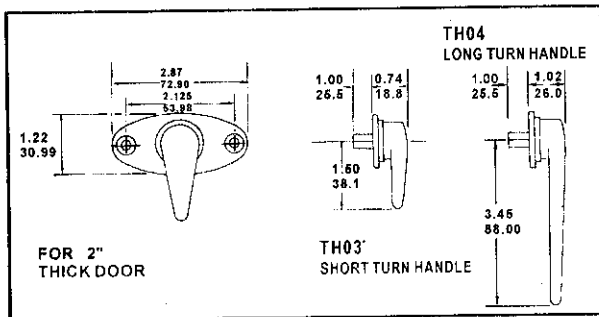
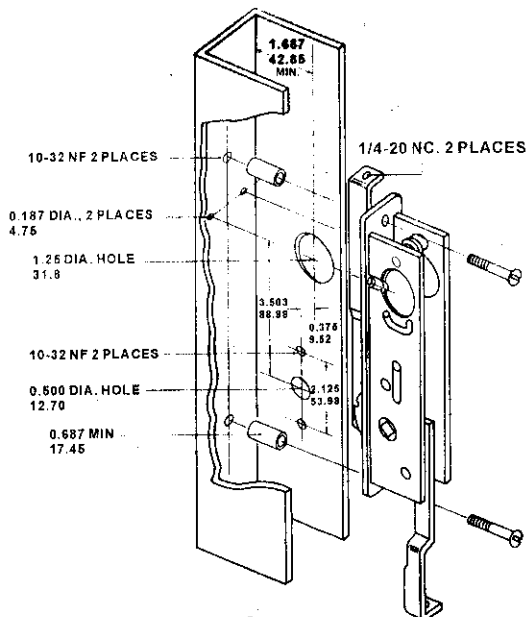

CYLINDER CAM

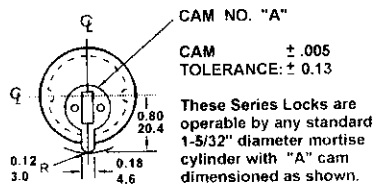

STANDARD PACKING:

Each set of No. 2954 Two-Point Deadlock contains 2 Pcs. No. TH03 zinc alloy turn handles & 1 set mounting screws individually packed in a box, 25 boxes per export carton.
N. W. 20 KGS. G. W. 22 KGS. M. 0.024 CBM